



Temperzone air conditioning units with UC8 controller board(s) can be connected to a standard BACnet control and monitoring network by a Modbus to BACnet converter. Temperzone provides a suitable converter called "Babel Buster". One Babel Buster can control up to four UC8 controllers. Communications follow the BACnet/IP protocol over a standard Ethernet computer network connection.

A BACnet controller / management system communicating with the UC8(s) via the Babel Buster is able to do the following:

- Turn compressor on and off.
- Monitor and control the indoor fan speed.
- Monitor and control cooling, heating, or fan only.
- Monitor and control unit capacity.
- Monitor and control de-icing of the outdoor coil.
- Monitor temperatures and pressures.
- Enable and disable de-humidification mode.
- Enable and disable quiet operating mode.
- Enable and disable economy operating mode.
- Enable and disable commissioning mode.
- Enable and disable supply air temperature control operating mode.
- Observe unit safety timers.
- Observe the state of inputs and outputs such as CMC relay, R/V relay etc.
- Observe information on reported faults.
- Restart a locked-out unit.

## Connections

Step 1:

Use a shielded twisted pair cable to connect the Babel Buster to the UC8 controller(s):

- Connect "12" from RS485 port 2 on any UC8 board to "POWER" on the Babel Buster

- Connect “G” from RS485 port 2 on the same UC8 to “GND” on the Babel Buster
- Connect “A1” from RS485 port 1 on the same UC8 to “NET+” on the Babel Buster
- Connect “B1” from RS485 port 1 on the same UC8 to “NET-” on the Babel Buster
- Connect in a parallel circuit all “A1” “B1” ports all UC8 boards for intended control.

Step 2:

Connect a standard Ethernet patch cable between the Babel Buster and an Ethernet network switch or hub. Alternatively connect directly to the Ethernet port on a computer using an Ethernet cross-over type cable.

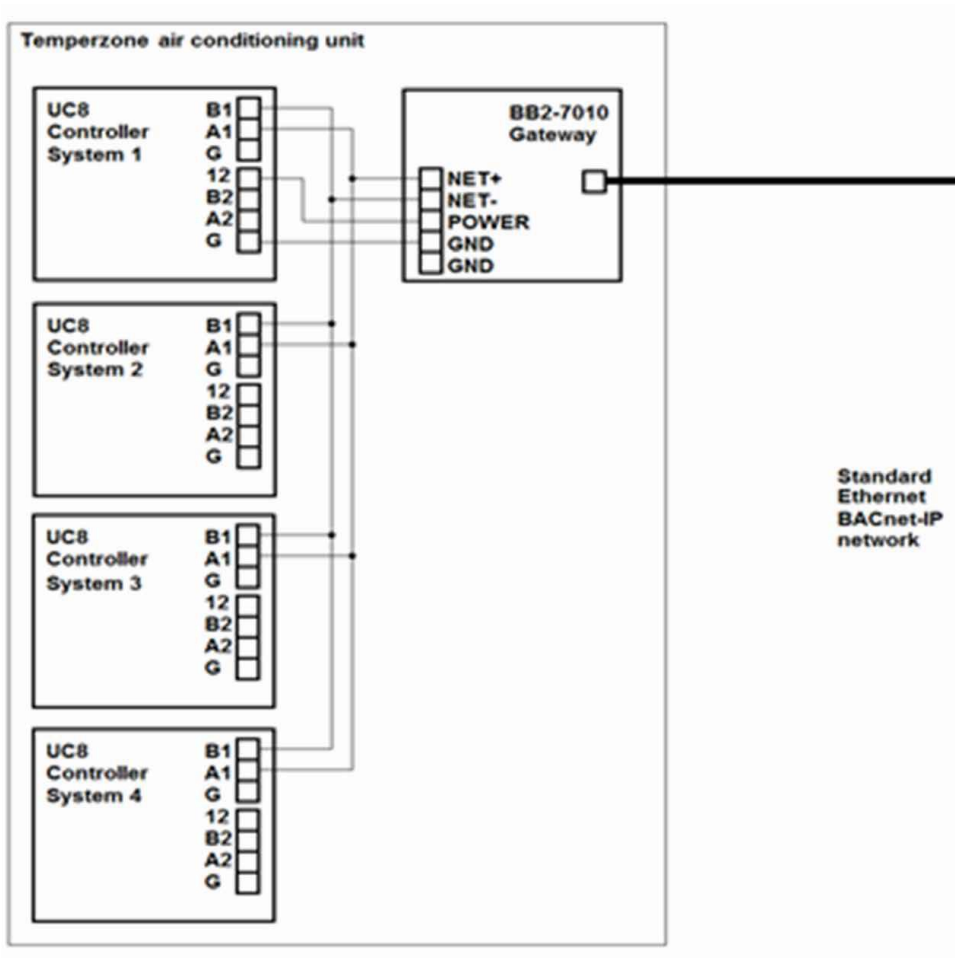

Step 3:

Configure UC8 DIP switches to master control. Each UC8 in the looped circuit will need to be configured as a “Master” board. This can be done by setting dip switches 11 and 12 to “OFF”.

Switch		Function
11	12	Master / Slave Selection
Off	Off	Master UC8
On	Off	Slave system (Nr. 2)
Off	On	Slave system (Nr. 3)
On	On	Slave system (Nr. 4)

Step 4:

Use the push-button on the second, third and fourth UC8 controllers to adjust the Modbus devices address from 44 to: 45 (second controller), 46 (third controller), 47 (fourth controller) (display option letter “A”, default value “44” = first UC8 controller).

## 2. Connections (Continued)

### UC8 Addressing Procedure

The default Modbus device address of the Temperzone UC8 controller is 44.

The controller offers a facility to view and change the Modbus device address. The procedure is as follows:

- The compressor must be off.
- There must be no request to start.

When the controller is in settings mode:

- Use short button presses to cycle through the available options (round-robin).
- A long button press confirms the selection made.

To change Modbus address in special mode:

1. Apply power to the unit and wait until the power-on sequence is completed. The display should show a blinking dash and decimal point, or just a blinking dash.
2. Press and hold down push-button SW3. After two seconds the display changes to show "0".
3. Release the button. The display will change to show "1".
4. Tap once to select menu '2' and long press to enter.
5. When the display says 'A' long press SW3 to enter.
6. The UC8 default address will display '44'. Use short presses to select desired Modbus address.
7. When the desired Modbus address is selected long press SW3 to confirm selection.
8. If the address was changed during address selection mode, then the controller will save new address in non-volatile memory. The new Modbus device address will be retained even after mains power has been switched off.

#### Step 5:

Depending on which Babel Buster software is installed, single dual or quad; baud rate of the UC8's may require adjustment.

There are 4 types of Babel Buster's with the following baud rates required.

Single: One UC8 Board - baud rate 19200 (UC8 Default).

Dual: Two UC8 Board - baud rate 19200 (UC8 Default).

Triple: Three UC8 Board - baud rate 38400.

Quad: Four UC8 Board - baud rate 38400.

Adjustment of baud rate is accessed via the special mode on the UC8. It is represented by the letter "b".

### Baud Rate Selection Procedure

The default baud rate of temperzone UC8 controller is 19200.

The controller offers a facility to view and change the baud rate. The procedure is as follows:

- The compressor must be off.
- There must be no request to start.

When the controller is in settings mode:

- Use short button presses to cycle through the available options (round-robin).
- A long button press confirms the selection made.

To change baud rate in special mode:

1. Apply power to the unit and wait until the power-on sequence is completed. The display should show a blinking dash and decimal point, or just a blinking dash.
2. Press and hold down push-button SW3. After two seconds the display changes to show "0".
3. Release the button. The display will change to show "1".
4. Tap twice to select menu '3' and long press to enter.
5. Tap once until the display says 'b' long press SW3 to enter.

6. The UC8 default baud rate (19200) will display as a "2". Use short presses to select desired baud rate.

Modbus Baud Rate Special Mode Selection		
Special Mode	Selection Options	Baud Rate
<b>b</b>	0	4800
	1	9600
	2	19200
	3	38400
	4	57600

7. When the desired Modbus address is selected long press SW3 to confirm selection.  
 If the address was changed during address selection mode, then the controller will save new address in non-volatile memory. The new Modbus device address will be retained even after mains power has been switched off.

**Step 6:**

Use a BACnet explorer to discover the Babel Buster on the network. The Babel Buster will be visible as an object with instance number 1.

**Step 7:**

Read the device object list.

**Step 8:**

The system is ready to monitor and control the unit.

**2.1. Babel Buster Specifications**

- Read/Write any standard Modbus register via BACnet objects
- 300 Non-commandable objects OR
- 135 Commandable objects OR
- Between 135 and 300 objects of mixed types.
- Object allocations are user configurable
- AI, AO, AV, BI, BO, BV, MSI, MSO, MSV objects
- COV, COVP subscription support
- BACnet slave is Modbus RTU master or vice versa
- Bidirectional communication between BACnet and Modbus
- Supports Modbus "coils", input registers, holding registers
- Single or double Modbus registers, signed, unsigned, IEEE 754
- Modbus register mapping configured via object properties
- Modbus registers may be scaled (x10, x100, x0.1, x0.01, etc.)
- Modbus (master) polling interval configurable per point
- Commandable BACnet objects implement priority array
- Fully configurable via BACnet object properties
- USB to MS/TP adapter available
- Configuration software included for use with USB adapter
- Hardened EIA-485 transceiver for serial ports
- MS/TP baud rates: 9600, 19200, 38400, 76800
- Modbus RTU baud rates: 4800, 9600, 19200, 38400
- Powered by 12-24V DC/AC 50/60 Hz
- Power Consumption: 0.1A @ 24VDC
- DIN rail mounting, 100mm H x 70mm W x 60mm D
- Pluggable screw terminal blocks
- Operating temperature -40°C to +85°C
- Humidity 5% to 90% non-condensing
- FCC, CE Mark, BTL Listed
- Listed to UL 916 and (Canadian) C22.2 No. 205-M1983

### 3. Object lists

The Babel Buster can connect to one, two, three or four UC8 controllers. Make sure to correctly specify the number of controllers when placing an order for the Babel Buster.

When the system connects to more than 1 UC8 controller identical sets of data are available for each individual controller. The table below provides the object ranges for each controller.

Object Type	Object Numbers							
	Unit 1		Unit 2		Unit 3		Unit 4	
	First	Last	First	Last	First	Last	First	Last
Analog input	1	100	101	200	201	300	301	400
Analog output	1	10	11	20	21	30	31	40
Analog value	1	30	31	60	61	90	91	120
Binary input	1	30	31	60	61	90	91	120
Binary output	Not used							
Binary value	1	30	31	60	61	90	91	120
Multistate input	1	10	11	20	21	30	31	40
MultiLstate output	Not used							
MultiLstate value	Not used							

Notes:

- The following paragraphs list the object number, name and function for “unit 1”. If the Babel Buster connects to more than one unit all objects are repeated for each unit with the object numbers offset as indicated in the table above. Examples:
 

Unit 1 condensing temperature	analog input object 10	U1_T_CO
Unit 2 condensing temperature	analog input object 110	U2_T_CO
Unit 3 condensing temperature	analog input object 210	U3_T_CO
Unit 4 condensing temperature	analog input object 310	U4_T_CO
- Not all objects have an assigned function. Such unused objects can be read from, written to or both in accordance with the object type, but doing so provides no information about the unit nor has any influence on operation of the unit.

#### 3.1. Analogue input objects

These objects can be used to collect information about the system.

Note:

Many units do not have all temperature sensors or pressure transducers fitted. For example, units with pressure transducers normally do not have temperature sensors fitted to the indoor and outdoor coils. Reading data from an object where the associated sensor is absent returns an out-of-range value, such as K100°C for a temperature sensor or K200 kPa for a pressure transducer.

Analog input objects for Unit1			
Nr.	Name	Function	Units
1	U1_ID	Controller: ID code (210 = UC8)	L
2	U1_SW	Controller: Software version (e.g. 205 = V2.0.5)	
3	U1_T_OC	Temperature: Outdoor coil	°C
4	U1_T_IC	Temperature: Indoor coil	
5	U1_T_OA	Temperature: Outdoor ambient	
6	U1_T_SL	Temperature: Compressor suction line	
7	U1_T_DL	Temperature: Compressor discharge line	
8	U1_T_DEI	Temperature: Outdoor coil de-ice sensor	
9	U1_T_EV	Temperature: Evaporating	
10	U1_T_CO	Temperature: Condensing	
11	U1_T_UC	Temperature: Controller board	
12	U1_SH_S	Superheat: Suction side	
13	U1_SH_D	Superheat: Discharge side	
14	U1_SH_C	Superheat: Calculated	
15	U1_P_SL	Pressure: Compressor suction line (evaporating)	kPa
16	U1_P_DL	Pressure: Compressor discharge line (condensing)	
17	U1_T_SA	Temperature: Supply air	°C
18	U1_T_RA	Temperature: Return air	
19	U1_T_SP	Temperature: Thermostat setpoint	
20	U1_T_RT	Temperature: Room	%
21	U1_EEV1	Expansion valve 1 opening	
22	U1_EEV2	Expansion valve 2 opening	
23	U1_FAN_OD_SPEED	Fan speed: Outdoor fan	
24	U1_FAN_ID_SPEED	Fan speed: Indoor fan	
25	U1_COMP_CAPACITY	Compressor: Capacity	
26	U1_COMP_FREQ	Compressor: Frequency (variable speed compressor only)	Hz
27	U1_COMP_CURRENT	Compressor: Current (variable speed compressor only)	A
28	U1_COMP_POWER	Compressor: Power (variable speed compressor only)	W
29	U1_COMP_VOLTAGE	Compressor: Voltage (variable speed compressor only)	V
30	U1_T_INVERTER	Temperature: Inverter (variable speed compressor only)	°C

**Analog input objects for Unit1 (Continued)**

<b>Nr.</b>	<b>Name</b>	<b>Function</b>	<b>Units</b>
31	U1_Timer_RUN	Timer: Minimum on-to-off ('run' timer)	s
32	U1_Timer_OFF	Timer: Minimum off-to-on ('off' timer)	
33	U1_Timer_CYCLE	Timer: Minimum on-to-on ('cycle' timer)	
34	U1_Timer_COOL_HOLD	Timer: Cooling mode hold-off	s
35	U1_Timer_HEAT_HOLD	Timer: Heating mode hold-off	
36	U1_Timer_DE_ICE	Timer: Outdoor coil de-icing	
37	U1_STAT_COOL_HOURS	Running hours, cooling	Hours
38	U1_STAT_COOL_MINUTES	Running minutes, cooling	Minutes
39	U1_STAT_HEAT_HOURS	Running hours, heating	Hours
40	U1_STAT_HEAT_MINUTES	Running minutes, heating	Minutes
41	U1_STAT_DEICE_HOURS	Running hours, de-icing	Hours
42	U1_STAT_DEICE_MINUTES	Running minutes, de-icing	Minutes
43	U1_STAT_CYC_COOL	Number of completed cooling cycles	L
44	U1_STAT_CYC_HEAT	Number of completed heating cycles	
45	U1_STAT_CYC_DEICE	Number of completed outdoor coil de-icing cycles	
46	U1_STAT_HP_TRIPS	Number of HP trips	
47	U1_STAT_LP_TRIPS	Number of LP trips	
48	U1_STAT_FROST_TRIPS	Number of indoor coil frost trips	
49	U1_STAT_FREEZE_TRIPS	Number of water freeze protection trips	
50	U1_STAT_Hi_DL_TRIPS	Number of compressor discharge side high temperature trips	
51	U1_STAT_Hi_EVAP_TRIPS	Number of compressor suction side high temperature trips	
52	U1_STAT_OL_TRIPS	Number of overload trips	
53	U1_STAT_Lo_DSH_TRIPS	Number of low discharge superheat trips	
54	U1_STAT_Hi_DSH_TRIPS	Number of high discharge superheat trips	
55	U1_STAT_IC_FAULTS	Number of indoor coil temperature sensor faults	
56	U1_STAT_OC_FAULTS	Number of outdoor coil temperature sensor faults	
57	U1_STAT_AMB_FAULTS	Number of outdoor ambient temperature sensor faults	
58	U1_STAT_DL_FAULTS	Number of compressor discharge line temperature sensor faults	
59	U1_STAT_SL_FAULTS	Number of compressor suction line temperature sensor faults	

Analog input objects for Unit1 (Continued)			
Nr.	Name	Function	Units
60	U1_STAT_DEI_FAULTS	Number of outdoor coil de-icing temperature sensor faults	L
61	U1_STAT_HPT_FAULTS	Number of high pressure transducer faults	
62	U1_STAT_LPT_FAULTS	Number of low pressure transducer faults	
63	U1_STAT_RV_FAULTS	Number of reverse cycle valve faults	
64	U1_STAT_IUC1_FAULTS	Number of faults reported by indoor unit controller 1	
65	U1_STAT_IUC2_FAULTS	Number of faults reported by indoor unit controller 2	
66	U1_STAT_VSD_FAULTS	Number of faults reported by compressor inverter	
67	U1_STAT_ENV_TRIPS	Number of out-of-compressor-operating-envelope trips	
68	-		
69	-		
70	U1_FAULT_CODE	Current fault code	

### 3.2. Analog output objects

This object can be used to unlock the controller.

Analog input objects for Unit1			
Nr.	Name	Function	Refer to section
1	U1_CNTRL_REG_RESET	Controller unlock and reset control	5.8 and 5.9

### 3.3. Analog value objects

These objects can be used to collect information about and to control some features of the system.

Analog input objects for Unit1					
Nr.	Name	Function	Units	Range	Refer to section
1	U1_REQ_DRED	Demand reduction (DRED)	L	0 to 3	K
2	U1_REQ_FAN	Indoor fan speed	%	0 to 100	5.2
3	U1_REQ_CAPACITY	Unit capacity			5.3
4	U1_PRM_SECURITY	Security code	L	K	
5	U1_PRM_CAP_PROP	Variable capacity proportional gain constant (P)	L	0 to 50	5.3.4
6	U1_PRM_CAP_INT	Variable capacity integration time	s	1 to 300	
7	U1_PRM_OILFLUSH_CAP	Oil flush cycle capacity threshold	%	0 to 80	5.3.1
8	U1_MODE_EEV	Expansion valve operating mode	L	0 to 3	5.4

### 3.4. Binary input objects

These objects can be used to view the current status of various binary (on/off) signals that are input to and output from the UC8 controller.

Binary input objects for Unit1		
Number	Name	Shows status of:
1	U1_IN_CP	CP input
2	U1_IN_HT	HT input
3	U1_IN_IN#1	IN#1 input
4	U1_IN_IN#2	IN#2 input
5	U1_IN_ROO	Remote on/off input
6	U1_IN_LO	LO input
7	U1_IN_ME	ME input
8	U1_IN_HI	HI input
9	U1_RLY_CMC	CMC output relay
10	U1_RLY_RV	RV output relay
11	U1_RLY_SSR1	SSR1 output relay
12	U1_RLY_SSR2	SSR2 output relay
13	U1_RLY_AUX	AUX output
14	U1_RLY_HIGH	HIGH output relay
15	U1_RLY_MED	MED output relay
16	U1_RLY_LOW	LOW output relay
17	U1_FN_DEICE_REQUEST	Set when the outdoor coil needs to be de-iced
18	U1_FN_DEICE_ACTIVE	Set when the controller is de-icing the outdoor coil
19	U1_FN_OILFLUSH	Set when the controller has activated oil flush mode
20	U1_FN_DRED	Set when the controller has switched the compressor off to meet DRED requirements

### 3.5. Binary output objects

No binary output objects are available.

### 3.6. Binary value objects

These objects can be used to control some features of the system.

The default values (active after every power-on and system reset) are indicated in with **bold letters**.

Binary value objects for Unit1		
Number	Name	Shows status of:
1	U1_EN_COMP	Enable (1) / <b>disable (0)</b> control over compressor
2	U1_EN_HEAT	Enable (1) / <b>disable (0)</b> control over cooling / heating
3	U1_EN_SPEED_FAN	Enable (1) / <b>disable (0)</b> control over indoor fan speed
4	U1_EN_CAPACITY	Enable (1) / <b>disable (0)</b> control over unit capacity
5	U1_EN_DEHUM	Enable (1) / <b>disable (0)</b> control over dehumidification
6	U1_EN_QUIET	Enable (1) / <b>disable (0)</b> control over quiet mode
7	U1_EN_ECONOMY	Enable (1) / <b>disable (0)</b> control over economy mode
8	U1_EN_REMONOFF	Enable (1) / <b>disable (0)</b> control over remote off / on
9	U1_EN_MODE_FAN	Enable (1) / <b>disable (0)</b> control over indoor fan mode
10	U1_EN_MODE_EEV	Enable (1) / <b>disable (0)</b> control over expansion valve mode
11	U1_EN_DRED	Enable (1) / <b>disable (0)</b> control over DRED input
12	U1_EN_DEICE	Enable (1) / <b>disable (0)</b> control over de-icing of the outdoor coil
13	U1_REQ_COMP	Request compressor <b>off (0)</b> or on (1)
14	U1_REQ_HEAT	Request <b>cooling (0)</b> or heating (1)
15	U1_REQ_DEHUM	Request dehumidification when cooling <b>off (0)</b> or on (1)
16	U1_REQ_QUIET	Request quiet mode <b>off (0)</b> or on (1)
17	U1_REQ_ECONOMY	Request economy mode <b>off (0)</b> or on (1)
18	U1_REQ_REMONOFF	Request remote off (0) or <b>on (1)</b>
19	U1_REQ_FAN_FIXED	Request indoor fan auto-speed (0) or <b>fixed speed (1)</b>
20	U1_REQ_FAN_ONMODE	Request indoor fan-auto mode (0) or <b>fan-on mode (1)</b>
21	U1_REQ_FAN_DEICEON	Request indoor fan off during de-ice (0) or <b>on during de-ice (1)</b>
22	U1_REQ_FAN_COOL	Request indoor fan heating warm start (0) or <b>cool start (1)</b>
23	U1_REQ_COMMISSIONING	Request commissioning mode <b>off (0)</b> or on (1)
24	U1_DEICE_PERMIT	<b>Allow (1)</b> or disallow (0) de-icing of the outdoor coil when the controller determines this is necessary
25	U1_DEICE_FORCE	When set forces the controller to start de-icing of the outdoor coil

### 3.7. Multi-state input objects

This object can be used to collect information about the system.

Multi-state input objects for Unit1			
Nr.	Name	Function	Refer to section
1	U1_MODE	Unit1 operating mode	4

### 3.8. Multi-state output objects

No multi-state output objects are available.

### 3.9. Multi-state value objects

No multi-state value objects are available

## 4. Unit status

The following objects provide basic information about current unit status.

### 4.1. Operating mode and fault code

Object	Name	Function	Values
<b>Multi-state input object 1</b>	U1_MODE	Current state of the unit	<ol style="list-style-type: none"><li>1. Off</li><li>2. Cooling Start</li><li>3. Cooling Run</li><li>4. Cooling End</li><li>5. Heating Start</li><li>6. Heating Run</li><li>7. Heating End</li><li>8. De-ice Start</li><li>9. De-ice Run</li><li>10. De-ice Dry</li><li>11. De-ice End</li><li>12. Lock Out</li></ol>

#### 4.1. Operating mode and fault code (Continued)

Object	Name	Function	Values
Analog input object 70	U1_FAULT_CODE	Current fault code	0 No faults 1. HP trip 2. LP trip 3. Overload 4. Indoor coil frost protection 5. Water freeze protection 6. High discharge temperature 7. High evaporation / suction temperature 8. Sump condensate flooding 9. No circulating water flow 10. Low discharge superheat 11. Outdoor fan fault 12. Indoor fan fault 13. Low pressure transducer fault 14. High pressure transducer fault 15. Suction line temperature sensor fault 16. Discharge line temperature sensor fault 17. Outdoor coil de-ice temp. sensor fault 18. Outdoor coil temperature sensor fault 19. Indoor coil temperature sensor fault 20. Outdoor ambient temperature sensor fault 21. Cannot calculate superheat 22. Thermostat communications lost 23. Master UC8 communications lost 24. Slave 1 UC8 communications lost 25. Slave 2 UC8 communications lost 26. Slave 3 UC8 communications lost 27. Cannot read UC8 DIP switches 28. Invalid fan selection 29. Outdoor coil de-ice sensor missing 30. Controller temperature too high 31. Controller supply voltage problem 32. Slave controller reports a problem 33. UC8 controller internal problem 34. High discharge superheat 35. Pressures not equalising 36. Reverse cycle valve problem 37. TZTK100 thermostat invalid DIP switch settings 38. Indoor unit (IUC) communications lost 39. Indoor unit (IUC) reports a problem 40. Compressor inverter (VSD) reports a problem 41. High compression ratio 42. Low compression ratio 43. High evaporating temperature 44. Low condensing temperature 45. - 46. - 47. - 48. -

## 4.2. Compressor, reverse cycle valve, indoor and outdoor fan status and capacity

Object	Name	Function	Values
Binary input object 9	U1_RLY_CMC	Current state of the compressor	0 = off 1 = on
Binary input object 10	U1_RLY_RV	Current position of the reverse cycle valve	0 = cooling position 1 = heating position
Analog input object 23	U1_FAN_OD_SPEED	Current state of the outdoor fan	0 = off 10 = low speed 55 = medium speed 100 = high speed
Analog input object 24	U1_FAN_ID_SPEED	Current state of the indoor fan	0 = off 10 = low speed 55 = medium speed 100 = high speed
Analog input object 25	U1_COMP_CAPACITY	Current operating capacity (duty)	0 = off 16 = minimum 100 = maximum

## 5. Unit control

This chapter gives details on control of the compressor, reverse cycle valve, indoor fan, capacity (duty), dry and quiet modes and how to unlock or reset the controller.

### 5.1. Compressor and reverse cycle valve

#### 5.1.1. Objects related to the compressor and reverse cycle valve

Default values present after power-up and controller reset are indicated with bold letters.

Object	Name	Function	Values
Binary value object 1	U1_EN_COMP	Control over compressor	<b>0 = disabled</b> 1 = enabled
Binary value object 2	U1_EN_HEAT	Control over cooling/heating	<b>0 = disabled</b> 1 = enabled
Binary value object 13	U1_REQ_COMP	Request compressor	<b>0 = OFF</b> 1 = ON
Binary value object 14	U1_REQ_HEAT	Request cooling or heating	<b>0 = cooling</b> 1 = heating
Binary value object 23	U1_REQ_COMMISSIONING	Request commissioning	<b>0 = OFF</b> 1 = ON
Binary input object 9	U1_RLY_CMC	CMC output relay:	0 = OFF                              1 = ON
Binary input object 10	U1_RLY_RV	R/V output relay:	0 = OFF                              1 = ON
Multi-state input object 1	U1_MODE	Current state of the unit (refer section 4)	

## 5.2. Indoor fan

### 5.2.1. Objects related to the indoor fan

Default values present after power-up and controller reset are indicated with bold letters.

Object	Name	Function
Binary value object 3	U1_EN_SPEED_FAN	BMS control over the speed of the indoor fan: 0 Disabled: Indoor fan speed is controlled from terminals on the UC8 (or IUC) or by a communicating thermostat. 1 Enabled: Indoor fan speed is controlled by BMS via BACnet.
Binary value object 9	U1_EN_MODE_FAN	BMS control over the behaviour of the indoor fan: 0 Disabled: Indoor fan behaviour is controlled by DIP switches on the UC8 and/or a communicating thermostat. 1 Enabled: Indoor fan behaviour is controlled by BMS via BACnet.

#### 5.2.1. Objects related to the indoor fan (Continued)

Object	Name	Function
Binary value object 19	U1_REQ_FAN_FIXED	0 The UC8 is allowed to automatically vary indoor fan speed to control the evaporating or condensing temperature. <b>The UC8 will not automatically vary indoor fan speed (unless required to protect the compressor).</b> 1
Binary value object 16	U1_REQ_FAN_ONMODE	0 The UC8 is allowed to stop the indoor fan when evaporating and/or condensing temperature are outside recommended values. 1 <b>The UC8 is not allowed to stop the indoor fan (even when pressure(s) and or temperature(s) are outside recommended values).</b>
Binary value object 17	U1_REQ_FAN_DEICEON	0 The indoor fan stops when the unit is de-icing the outdoor coil. 1 <b>The indoor fan continues to run when the unit is de-icing the outdoor coil.</b>
Binary value object 18	U1_REQ_FAN_COOL	0 The indoor fan may stop when the unit starts in heating mode, but the indoor coil has not yet warmed up. 1 <b>The indoor fan continues to run when the unit starts in heating mode.</b>
Analog value object 2	U1_REQ_FAN	<b>0 Request indoor fan to stop.</b> 10 Request indoor fan run at minimum speed. 55 Request indoor fan run at medium speed. 100 Request indoor fan run at maximum speed.
Analog input object 24	U1_FAN_ID_SPEED	0 Indoor fan is stopped. 10 Indoor fan is running at minimum speed. 55 Indoor fan is running at medium speed. 100 Indoor fan is running at maximum speed.

Notes:

- If certain temperatures and/or pressures are outside values required for reliable operation the controller may protect the system by changing the indoor fan speed to a value different from that written to the indoor fan

speed control object.

- If an application requires that indoor fan speed must never change regardless of operating conditions, then the controlling BMS may bypass the UC8 controller and directly connect to the indoor fan. In such applications it is the responsibility of the system designer, installer and end- user to ensure unit reliability. As always: Should the controller detect sustained running outside safe operating conditions, safety protection mechanisms may operate and, if the protection mechanisms need to operate repeatedly, the unit may eventually be locked out.
- If the compressor is running but there is no request for the indoor fan to run then the UC8 controller automatically runs the indoor fan at minimum speed.

### 5.2.2. Single speed fans

To gain control over the indoor fan write value 1 to binary value object 3 (U1\_EN\_SPEED\_FAN). Thereafter write to analog value object 2 (U1\_REQ\_FAN) to control the indoor fan.

Valid values that can be written to U1\_REQ\_FAN range from 0 to 100. Single speed indoor fan control is as follows:

- If the fan is off, then any value from 5 to 100 starts the fan. For values from 0 to 4 the fan remains off.
- To stop a running fan use value 0; any other value leaves the fan on. Suggested control values for single-speed indoor fans are:
  - Write value 0 to stop the indoor fan
  - Write value 100 to start the indoor fan

### 5.2.3. Three speed fans

To gain control over the indoor fan write value 1 to binary value object 3 (U1\_EN\_SPEED\_FAN). Thereafter write to analog value object 2 (U1\_REQ\_FAN) to control the indoor fan speed.

- Valid values that can be written to U1\_REQ\_FAN range from 0 to 100. Three-speed indoor fan control is as follows:
- Value 0 stops the fan. However, if the compressor is still on then the controller will overrule the command and continue to run the fan on low speed.
- If the fan is off, then a value of 5 and higher starts the fan. For values from 0 to 4 the fan remains off.
- If fan speed is low, then a value of 0 stops the fan, a value of 45 and higher switches fan speed up. For values from 1 to 44 the fan speed remains low.
- If fan speed is medium, then a value of 34 or lower reduces fan speed, a value of 80 or higher increases fan speed to high. For values from 35 to 79 the fan speed remains medium.
- If fan speed is high, then a value of 69 or lower reduces fan speed. For values from 70 to 100 the fan speed remains high.

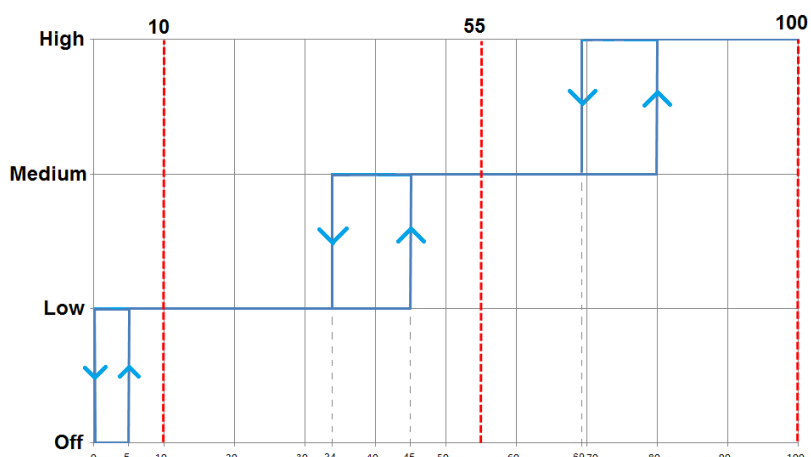

Beside is a graphical representation of the conversion from 0K100 to Off-Low-Medium-High.

Suggested control values for three-speed indoor fans are:

- Write value 0 to stop the indoor fan
- Write value 10 to run the indoor fan on low speed
- Write value 55 to run the indoor fan on medium speed
- Write value 100 to run the indoor fan on high speed

### 5.2.4. Variable speed fans

To gain control over the indoor fan write value 1 to binary value object 3 (U1\_EN\_SPEED\_FAN). Thereafter write to analog value object 2 (U1\_REQ\_FAN) to control the indoor fan speed. Valid values that can be written to U1\_REQ\_FAN range from 0 to 100. Continuously variable speed indoor fan (EC fan) control is as follows:

- Value 0 will stop the fan. However, if the compressor is still on then the controller will overrule the stop command and the fan will continue running on minimum speed.
- If the fan is off, then a value of 5 or higher starts the fan. For values from 0 to 4 the fan remains off.
- For values from 5 to 10 the indoor fan runs on minimum speed.
- For values from 10 to 100 the indoor fan speed linearly varies from minimum to maximum.

Actual minimum and maximum fan speeds can be adjusted by using the button and display on the UC8 controller or by using indoor fan speed setup mode on a SAT-3 thermostat. If the system is a split unit with an IUC fitted in the indoor unit then indoor fan speed can also be set by DIP switches on the IUC. For more information on fan speed adjustment refer to document "Temperzone UC8 Operation and Installation – Air Cooled Units".

Beside is a graphical representation of the conversion from 0K100 to off & minimum to maximum.

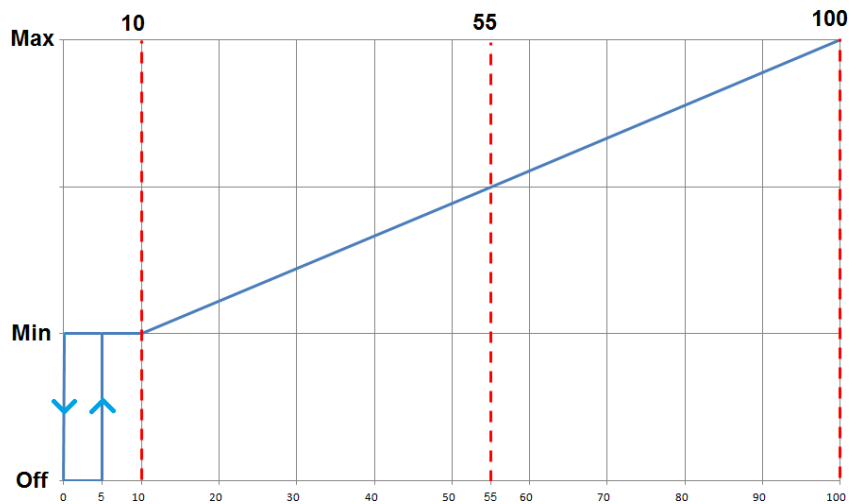

### 5.3. Capacity

If a unit is equipped with a variable speed compressor or a digital scroll compressor, then it is possible to vary capacity (duty) of the unit. Capacity control is not possible for a unit with a fixed duty compressor. The following sections give details of objects for control and status of unit capacity.

#### 5.3.1. Objects related to capacity

Objects related to unit capacity are:

Object	Name	Function
Analog input object 25	U1_COMP_CAPACITY	Current unit capacity (0 to 100%)
Analog value object 3	U1_REQ_CAPACITY	Requested unit capacity (0 to 100%, <b>default 50%</b> )
Binary input object 19	U1_FN_OILFLUSH	Set when the controller has activated oil flush mode
Binary value object 4	U1_EN_CAPACITY	Enable (1) / <b>disable (0)</b> control over unit capacity

#### 5.3.2. Minimum and maximum capacity

The following table gives a list of capacities available:

Compressor Type	Minimum Capacity		Nominal Capacity	Boost Mode Capacity
	Close Control	Standard Control		
<b>Fixed Duty</b>			100%	
<b>Digital Scroll</b>	16%	40%		100%
<b>Variable Speed</b>	15%	40%	75%	100%

Notes:

- UC8 DIP switch 14 selects minimum capacity: OFF = Standard control, ON = Close control.

- The UC8 controller enforces a minimum capacity. If the compressor is running, then the unit capacity will normally be equal to that as dictated by the BMS unless the BMS requests a capacity less than the allowed minimum.
- The UC8 controller may automatically alter capacity from the requested value in order to avoid undesirable operating conditions and trips. However, capacity will never be reduced to less than standard control minimum nor will capacity be automatically increased above nominal (values as per the table above). Example:
- When a unit is cooling then capacity may automatically be reduced, to a minimum of 40%, to avoid frost (ice) forming on the indoor coil.
- Operating a unit with a variable speed compressor at higher than nominal capacity (“boost mode”) is possible and permitted but we recommend this to be for limited duration only. When a unit is operated in boost mode then unit efficiency may be less than optimum and increased noise may be apparent.

### 5.3.3. Start-up capacity

During the first two minutes following a start of the compressor the capacity may differ from the value dictated by the BMS or 0K10V capacity input. This is done to return to the compressor any lubricating oil that may have settled elsewhere in the system. Following these first two minutes the minimum and maximum capacities revert to the values listed in paragraph 5.3.2.

Compressor type	Start-up capacity	
	Minimum	Maximum
Fixed duty	100%	
Digital scroll	75%	100%
Variable speed	50%	

### 5.3.4. Autonomous capacity

There are three installations where the UC8 controller can autonomously control capacity. These are:

1. The unit is controlled by a SAT-3, or a TZT-100 wall thermostat.
2. The unit is controlled by a Temperzone ZONE controller.
3. The unit is configured to autonomously control the supply air temperature.

The following applies only to installations with the unit controlled by a SAT-3 or TZT-100 wall thermostat. (Installations 2 and 3 are not discussed in this document.)

#### 5.3.4. Autonomous capacity (Continued)

The UC8 interrogates the wall thermostat to obtain the current values for the room temperature and the setpoint. This information is then used in a closed loop control function with proportional and integrating control (PI). The PI function controls unit capacity attempting to make the room temperature equal to the setpoint and hold it there steadily. Depending on the load at the time and the size of the unit doing so may take any capacity from 0 to 100%, the PI function will make the unit deliver the required capacity.

The “reactiveness” of the PI function can be controlled with the following objects:

Object	Name	Function	Units	Range
Analog value object 5	U1_PRM_CAP_PROP	Variable capacity proportional gain constant (P)	L	0 to 50 (default 45)
Analog value object 6	U1_PRM_CAP_INT	Variable capacity integration time constant (I)	s	1 to 300 (default 40s)

It is possible that for some installations the PI function varies capacity too fast. This can lead to the unit capacity endlessly varying up and down while the room temperature swings above and below the desired setpoint. In

such a case control may be improved by reducing the proportional gain and/or increasing the integration time constant.

If the opposite is the case and capacity varies very slowly despite a large differential between the room temperature and the setpoint then one can increase the proportional gain and/or reduce the integration time constant.

**Note:** It is necessary to first write value 8821 (hexadecimal 0x2275) to analog value object 4 (U1\_PRM\_SECURITY) before the UC8 controller will accept new values for U1\_PRM\_CAP\_PROP and U1\_PRM\_CAP\_INT.

### 5.3.5. Oil flush capacity

To return to the compressor any lubricating oil that may have settled elsewhere in the system the controller can impose oil flush cycles. Oil flush cycles are activated only when the compressor has remained on with capacity continuously remaining relatively low for an extended period of time. By default, this period of time is 1 hour and 40 minutes. Oil flush cycles last only for 1 minute. During an oil flush cycle, the unit capacity will differ from the value as dictated by BMS or 0K10V input.

## 5.4. Dry mode (dehumidification)

Dehumidification mode can provide increased cooling comfort by removing moisture from the supply air. Dehumidification relies on methods that bring the indoor coil evaporating temperature below the dew point. This causes moisture to condense on the indoor coil and so be removed from the supply air. The UC8 controller offers a number of methods by which dehumidification can be achieved.

Which method is used depends on the user requirements and preferences and the unit capabilities.

- Normal cooling mode is available on all unit models. Moisture will be removed from the supply air only if the temperature of the indoor coil is below the dew point. If it is desirable to expressly not remove moisture from the air but cooling is still required (the room is warm and relative humidity is normal or low) then operate the unit in normal cooling mode. Selecting a high indoor fan speed can also help to retain moisture in the supply air.
- Conventional dehumidification mode relies on automatic control over the indoor fan speed. Conventional dehumidification is available on all models except units with a fixed speed indoor fan. This method is unsuitable for applications where the volume of supply air must remain constant. In this mode the UC8 controller takes control over the speed of the indoor fan. There is no need to control objects related to the indoor fan other than the objects listed above.
- Advanced dehumidification mode is available only on models with dual expansion valves and split indoor coil. Indoor fan speed can remain constant making this method suitable for applications where the volume of supply air must remain constant. It is also suitable for units with single-speed indoor fan.
- Super dehumidification mode is available only on models with dual expansion valves and split indoor coil. This method combines advanced and conventional dehumidification modes as described above. Super dehumidification is not suitable for applications where the volume of supply air must remain constant. It is also unsuitable

The table below lists the BACnet objects associated with control over dehumidification and the values to write to the objects to select the desired mode.

<b>Normal Cooling</b>	0 or 1	0 or 1	0 or 1	0	0 or 1	0
<b>Conventional Dehumidification</b>	1	1	0	0	0 or 1	1
<b>Advanced Dehumidification</b>	1	1	1	1	3	1
<b>Super Dehumidification</b>	1	1	0	1	3	1
<b>Mode</b>	Binary value object 5 U1_EN_DEHUM	Binary value object 9 U1_EN_MODE_FAN	Binary value object 19 U1_REQ_FAN_FIXED	Binary value object 10 U1_EN_MODE_EEV	Analog value object 8 U1_MODE_EEV	Binary value object 15 U1_REQ_DEHUM

The objects listed in the table need to be written to only once after each power-on or reset of the UC8 controller. Once the objects are set to the values indicated one can start and stop the unit in cooling mode as normal. It is allowed to write to binary value object 15 (U1\_REQ\_DEHUM) while a unit is cooling to switch between normal cooling (value 0) or cooling with dehumidification (value 1).

Writing a value to analog value object 8 (U1\_MODE\_EEV) is successful only when UC8 DIP switches 7 and 8 are both set to ON and only values 1 and 3 will be accepted; all other values are rejected. If DIP switch 7 and/or 8 is/are OFF, then any write action to this object has no effect.

When a unit is cooling with conventional dehumidification enabled there is no need to control the indoor fan, since the UC8 will automatically control the indoor fan speed. When operating in any other one should control the indoor fan as normal (refer to chapter 5.2).

### 5.5. Quiet mode

Quiet mode can reduce the amount of noise produced by the outdoor fan(s). The method used to obtain a quieter outdoor fan is by setting a different target for the condensing temperature (when cooling) or evaporating temperature (when heating). Quiet mode has no effect on the indoor fan nor on unit capacity (duty).

Enabling quiet mode can be effective when a unit is cooling, and the outdoor ambient temperature is below about 35°C. Higher outdoor ambient temperatures reduce the effectiveness; quiet mode is not effective when cooling and the outdoor ambient temperature is above 40°C.

Similarly, enabling quiet mode can be effective when a unit is heating, and the outdoor ambient temperature is above about 15°C. Lower outdoor ambient temperatures reduce the effectiveness; when heating while the outdoor ambient temperature is below 10°C then enabling quiet mode will have no effect.

If a unit is equipped with a variable speed or a digital scroll compressor, then reducing capacity can also aid in achieving quieter unit operation.

### 5.5.1. Objects are associated with control over quiet mode

Binary value object 6	U1_EN_QUIET	Enable (1) / <b>disable (0)</b> control over quiet mode
Binary value object 16	U1_REQ_QUIET	Request quiet mode <b>off (0)</b> or on (1)

## 5.6 De-icing the outdoor coil

### 5.6.1. Objects associated with de-icing the outdoor coil

Analog input 5	U1_T_AMB	Outdoor ambient temperature	°C
Analog input 8	U1_T_DEI	Outdoor coil de-ice sensor temperature	
Analog input 9	U1_T_EV	Evaporating temperature	
Analog input 36	U1_Timer_DEICE	Outdoor coil de-icing timer	seconds
Binary input 17	U1_FN_DEICE_REQUEST	Set when the controller has determined that the outdoor coil requires to be de-iced	
Binary input 18	U1_FN_DEICE_ACTIVE	Set when the controller is de-icing the outdoor coil	
Binary value 12	U1_EN_DEICE	BMS control over de-icing: <b>0 = Disabled</b> (UC8 autonomous control) 1 = Enabled	
Binary value 9	U1_EN_MODE_FAN	BMS control over indoor fan operating mode: <b>0 = Disabled.</b> 1 = Enabled	
Binary value 21	U1_REQ_FAN_DEICEON	Indoor fan operation during de-icing: 0 = Off <b>1 = On</b>	
Binary value 24	U1_DEICE_PERMIT	<b>Allow (1)</b> or disallow (0) de-icing of the outdoor coil when the controller determines this is necessary	
Binary value 25	U1_DEICE_FORCE	When set forces the controller to start de-icing of the outdoor coil	

### 5.6.2. Indoor fan operation during de-icing of the outdoor coil

- During de-icing of the outdoor coil, it is possible to either leave the indoor fan running or to stop the indoor fan. In general:
- Stopping the indoor fan during a de-ice cycle avoids cold air being blown into the room. However, usually it causes the de-icing operation to take longer than when the indoor fan is allowed to continue running. Use this option when the application has no requirements for delivery of a minimum air volume and delivery of cold air into the room is not acceptable.
- Leaving the indoor fan running during a de-ice cycle will cause cold air to be blown into the room. However, usually it helps to shorten the duration of the de-ice cycles. Use this option when the application requires delivery of a minimum air volume.

The UC8 provides the following options for control of the indoor fan during de-ice cycles:

Binary value 9 (U1\_EN\_MODE\_FAN) = 0:

Operation of the indoor fan during outdoor coil de-ice cycles is determined either by a SATR3 or TZTR 100 wall thermostat (if present) or, if no wall thermostat is connected, by UC8 DIP switch 1.

- Wall thermostat: Fan-Auto mode allows the indoor fan to stop.  
Fan-On mode requires the indoor fan to continue running.
- UC8 DIP switch 1: OFF allows the indoor fan to stop.  
ON requires the indoor fan to continue running.

Binary value 9 (U1\_EN\_MODE\_FAN) = 1:

The BMS controls operation of the indoor fan when the unit is de-icing the outdoor coil. BMS control is then possible via binary value 21:

- U1\_REQ\_FAN\_DEICEON = 0: Allow the indoor fan to stop.
- U1\_REQ\_FAN\_DEICEON = 1: Require the indoor fan to continue running.

### 5.6.3. BMS control of outdoor coil de-ice cycles

BMS control over de-ice cycles is especially useful for installations with more than one compressor. In such installations the BMS can monitor operating conditions, then allow and disallow units to de-ice in order to optimise user comfort and unit performance. For example, in an installation with four compressors the BMS could be programmed to allow only one or perhaps two systems to de-ice at any time while using the other two systems to continue heating.

The following objects can be monitored by the BMS to obtain de-icing status information:

Object	Name	Function
Binary input object 17	U1_FN_DEICE_REQUEST	Set when the controller has determined that the outdoor coil requires de-icing
Binary input object 18	U1_FN_DEICE_ACTIVE	Set when the controller is de-icing the outdoor coil
Multi state input object 1	U1_MODE	Reflects the current mode of the unit (off, cooling, heating, de-icing, ...)

The UC8 provides the following objects for control of outdoor coil de-ice cycles.

Object			Operation
Binary value 12 U1_EN_DEICE	Binary value 24 U1_DEICE_PERMIT	Binary value 25 U1_DEICE_FORCE	
0	Any (defaults to 1)	Any	UC8 autonomous control
1	0	0	De-icing is not allowed.
1	1	0	The UC8 is allowed to de-ice when necessary.
1	Any	1	Immediately start a de-ice cycle.

- Notes:
  - Using binary value 25 (U1\_DEICE\_FORCE) to force the unit to start a de-ice cycle is effective only when the unit is heating and has done so for more than 2 minutes.
- When using forced de-ice cycles via binary value 25 (U1\_DEICE\_FORCE) the object value is automatically reset to 0 as soon as the de-ice cycle has commenced. However, the object update rate is once a minute which can cause up to one minute delay before this is reported in the object value.

Should one wish to forcibly end a de-ice cycle the recommended method is to remove the request for heating, preferably by writing value 0 to binary value object 13 (U1\_REQ\_COMP). Doing so will make the UC8 immediately advance to the “de-ice dry” and “de-ice end” modes, followed by “off”.

Completing this sequence takes about 1 minute; thereafter the unit can be restarted heating if desired.

**Caution:**

When the BMS controls de-icing of the outdoor coil care must be exercised that de-icing occurs regularly enough not to impair unit operation. Too infrequent de-icing can cause severe blocking of the outdoor coil and lead to LP trips and unit lock-out.

**57. Dynamic demand reduction (DRED)**

Dynamic demand reduction (DRED) allows an external device to reduce the energy consumption of the air conditioning system. There are four levels of demand reduction:

- 0 Normal operation: Up to 100% of rated energy consumption.
- 1 Minimum energy consumption. The compressor will be held off, but the indoor fan is allowed to continue running.
- 2 Up to 50% of rated energy consumption.
- 3 Up to 75% of rated energy consumption.

Levels 2 and 3 are achieved by switching the compressor off for part of half-hour intervals.

The following objects are associated with control over demand reduction (default values in bold):

Object	Name	Function
Binary value object 11	U1_EN_DRED	Enable (1) / <b>disable (0)</b> control over DRED
Analog value object 1	U1_REQ_DRED	Level <b>0</b> to 3

**58. Resetting the controller**

The controller can be reset using one of the following methods.

**Warning!**

Use caution when using BACnet to reset the controller! After receiving the correct command sequence the unit immediately performs a full system reset, regardless of the current unit operation! The controller restarts in the same way as when mains power to the unit is switched on. Normal operation can resume after about 30 seconds to 1 minute.

**Method 1.** Switch mains power to the controller off, wait for at least 5 seconds, then switch mains power back on again.

**Method 2** Use BACnet communications to send the following two commands to the controller.

Commands must be given in the order listed here:

- Write value 8821 (hexadecimal 0x2275) to analog value object 4: U1\_PRM\_SEC.
- Write value 4660 (hexadecimal 0x1234) to analog output object 1: U1\_CNTRL\_RESET.
- No specific timing requirements exist for the above two commands.

## 5.9. Unlocking a unit

A unit is locked out when a serious fault occurs three times within a 12-hour period and the request for compressor-on has remained continuous. Faults that have occurred longer than 12 hours ago are removed from the count. Fault counts are reset to zero every time the unit switches off normally, either by the thermostat, by BMS or by mains power off.

When a unit is locked out it will not run the compressor or the indoor and outdoor fans. A locked-out unit reports value 12 (Lock Out) in multi-state input object 1 (U1\_MODE).

When mains power is applied to a controller that was locked out, or the controller is reset, the display shows the cause of the previous lock-out for 20 seconds. This message will stop appearing after the unit has completed at least one full normal cooling or heating cycle.

A unit that is locked-out can be un-locked using one of the following methods:

Method 1. Switch mains power to the controller off, wait for at least 5 seconds, then switch mains power back on again.

Method 2. Use BACnet communications to send the following two commands to the controller.

Commands must be given in the order listed here:

- Write value 21930 (hexadecimal 0x55AA) to analog output object 1: U1\_CNTRL\_RESET.
- Write value 3855 (hexadecimal 0x0F0F ) to analog output object 1: U1\_CNTRL\_RESET.
- The second command must be sent within 10 seconds following the first command.

After receiving the above two commands in the correct order and with the correct timing the unit mode returns from "Lock Out" to "Off" (to monitor unit mode read multi-state input object 1 U1\_MODE). The unit is then immediately ready to restart normal operation. If the commands are sent to the unit when the unit was not locked out, or more than 10 seconds elapse between the two commands, or the commands are sent in an incorrect order then the commands have no effect.

Method 3. Reset the controller. Refer to section 5.8.

## 5.10. Control example

The following example shows how BACnet communications can be used to control an air-cooled reverse cycle unit (unit 1) with a variable speed indoor fan and variable capacity. The procedure is the same for other units, if present, adjusting the object numbers according to the unit number.

The following write-actions are required once only after every power-on and system reset (repeated writes are allowed):

Object	Name	Action	Purpose
Binary value object 1	U1_EN_COMP	Write value 1	Gain control over compressor off and on
Binary value object 2	U1_EN_HEAT	Write value 1	Gain control over cooling or heating
Binary value object 7	U1_EN_SPEED_FAN	Write value 1	Gain control over the indoor fan speed
Binary value object 8	U1_EN_CAPACITY	Write value 1	Gain control over unit capacity

The following write-actions are required when changing an aspect of unit operation:

Object	Name	Action	Purpose
Binary value object 13	U1_REQ_COMP	Write value 0 = off 1 = on	Switch the compressor off or on
Binary value object 14	U1_REQ_HEAT	Write value 0 = cooling 1 = heating	Select cooling or heating
Analog value object 2	U1_REQ_FAN	Write value 0 to 100	Set the indoor fan speed (refer to chapter 5.2)
Analog value object 3	U1_REQ_CAP	Write value 0 to 100	Set the unit capacity (refer to chapter 5.3)

### Notes

- Regardless of how a unit is controlled, safety features built into the unit are always applied. For example: A compressor can be held off until the minimum off-time has expired, and this delay will always be applied independent of the request received via BACnet.
- When mains power is removed from the unit and then re-applied all control objects always are reset to their default values. To re-gain control over a unit after mains power has been interrupted, or after the controller has been reset, a BMS must again write to the appropriate control-enable objects (binary value objects 1 to 12, U1\_EN\_XXX).
- Objects associated directly with unit control and active state monitoring are updated once every 5 seconds. However, many other objects, for example objects that provide status information with values that normally remain static or infrequently change value have much slower update rates, such as once a minute or once every 10 minutes.
- When a Babel Buster is used to control more than one UC8 controller then often there will be some delay between a command being issued and the response of the targeted controller. This is normal and not a malfunction.